



Segmental Retaining Wall Systems for Every Environment



by Colinwell



▲ Colour: Slate



▲ Colour: Cinder

Contents

- About Colinwell 3
- What is Allan Block®? 4
- Why Choose Allan Block®? 6
- The Allan Block® Collection 8
- Project Portfolio 12
- Allan Block® Colour Range 22
 - Gravity Walls 24
 - Reinforced Walls 27
 - Wall Detailing 35
 - How to Specify 42
- Our Accreditations 43

About Colinwell

Colinwell, a RTU company, is an award-winning company and a market leader in the concrete products industry. With over 130 years of experience, Colinwell has earned a strong reputation for producing best-in-class concrete products that combine performance, durability, and design excellence.

Our diverse product range includes Allan Block® Retaining Wall Systems, Martello Stone Walling, Architectural Masonry, and Acoustic Masonry Solutions. These innovative systems are designed to meet the needs of a wide variety of projects, providing both functional and aesthetic value.

Colinwell proudly serves a broad range of sectors, including education, industrial, infrastructure, residential, commercial, sports and recreation, and religious developments. Our ability to deliver dependable and tailored solutions has made us a trusted name across these industries.

We ensure our clients receive the right products, at the right time, and in the right place – backed by expert support and a deep understanding of construction needs. We supply projects of all sizes throughout the UK & Ireland, offering nationwide delivery and service our clients can rely on.

Our vision is to be the leading supplier of concrete masonry products – a goal we pursue through our core values of innovation, passion, and quality.

We are committed to sustainability, integrating environmentally conscious practices across our manufacturing processes and product designs. Colinwell continues to build on its legacy of excellence, combining heritage, innovation, and quality in every product we deliver.

Allan Block® Retaining Wall System

Engineered Strength.
Effortless Design.
Proven Longevity.



What is Allan Block®?

Allan Block® is a world-leading, patented system of segmental retaining wall blocks designed for superior performance, effortless installation, and long-term durability. Manufactured under licence by Colinwell to the highest standards through British Board of Agrément (BBA) Certification, Allan Block® systems offer a design life of over 120 years.

Suitable for everything from residential gardens to major infrastructure, Allan Block® carries a BBA / HAPAS certificate approved for use on all road related projects requiring compliance with the Highways Agency (GB), Roads Service (NI), and Transport Infrastructure Ireland (TII) specifications.

Whether you're building a small gravity wall or a tall load bearing engineered structure, Allan Block® offers unmatched design flexibility with innovative reinforcement options.



▲ Colour: Slate



Why Choose Allan Block®?

Not all retaining wall systems are created equal. Colinwell's Allan Block® collection combines engineering innovation, construction efficiency, and certified durability - all backed by our international partners at Allan Block® US and unmatched in-house technical support.

Patented Chamfered Edge Design with Anti-Climb Safety

Allan Block®'s exclusive interlocking front lip creates a built-in setback, eliminating the need for pins, clips, or mortar - making installation faster, cleaner, and more secure. The patented chamfered edge not only enhances aesthetics but also creates an anti-climb surface, which means when the wall is constructed it cannot be climbed.

Free Site-Specific Preliminary Design

Our in-house design team offers a free preliminary design service tailored to your project's unique requirements. With a hands on, problem solving approach and a deep understanding of site specific challenges, our team goes above and beyond to deliver solutions that are practical, innovative, and cost effective.

Versatile by Design

Choose from our family of Allan Block®s with 1°, 3°, 6°, or 12° setback angles, each with hollow cores and anti-climb chamfers to support a range of retaining scenarios, with consideration to design goals, site constraints and budget.

Colour Range That Complements Any Landscape

Available in five contemporary colour options, Allan Block® helps you achieve both functional performance and aesthetic impact.

Limitless Height Options

From small garden walls to tall, load bearing structures, Allan Block® systems can be tailored to any height requirement.

Superior Connection Strength

Allan Block® units are designed to work seamlessly with Geogrid reinforcement, providing industry leading connection strength between the block face and the soil mass. This results in increased stability for taller walls, even under high surcharge or poor soil conditions.

Continuous Connection with Geogrid Reinforcement

Our Continuous Connection System uses a PVC connection bar integrated with specially notched Allan Block® units to deliver a mechanical interlock with the Geogrid. This method provides greater connection strength, improved load resistance, and increased design flexibility - making it ideal for heavily loaded or critical structures when required.

Performance You Can Trust

Independently tested and certified to BBA HAPAS (Roads & Bridges) standards, ensuring compliance with all major road and infrastructure approval bodies in the United Kingdom and Republic of Ireland.

Sustainable & Strong

Manufactured using a controlled mixture of aggregates (65% recycled secondary aggregate content) and cement. The blocks meet BS EN 8500-1, BS EN 206-1 and BS EN 771-3 with an expected lifespan of over 120 years.

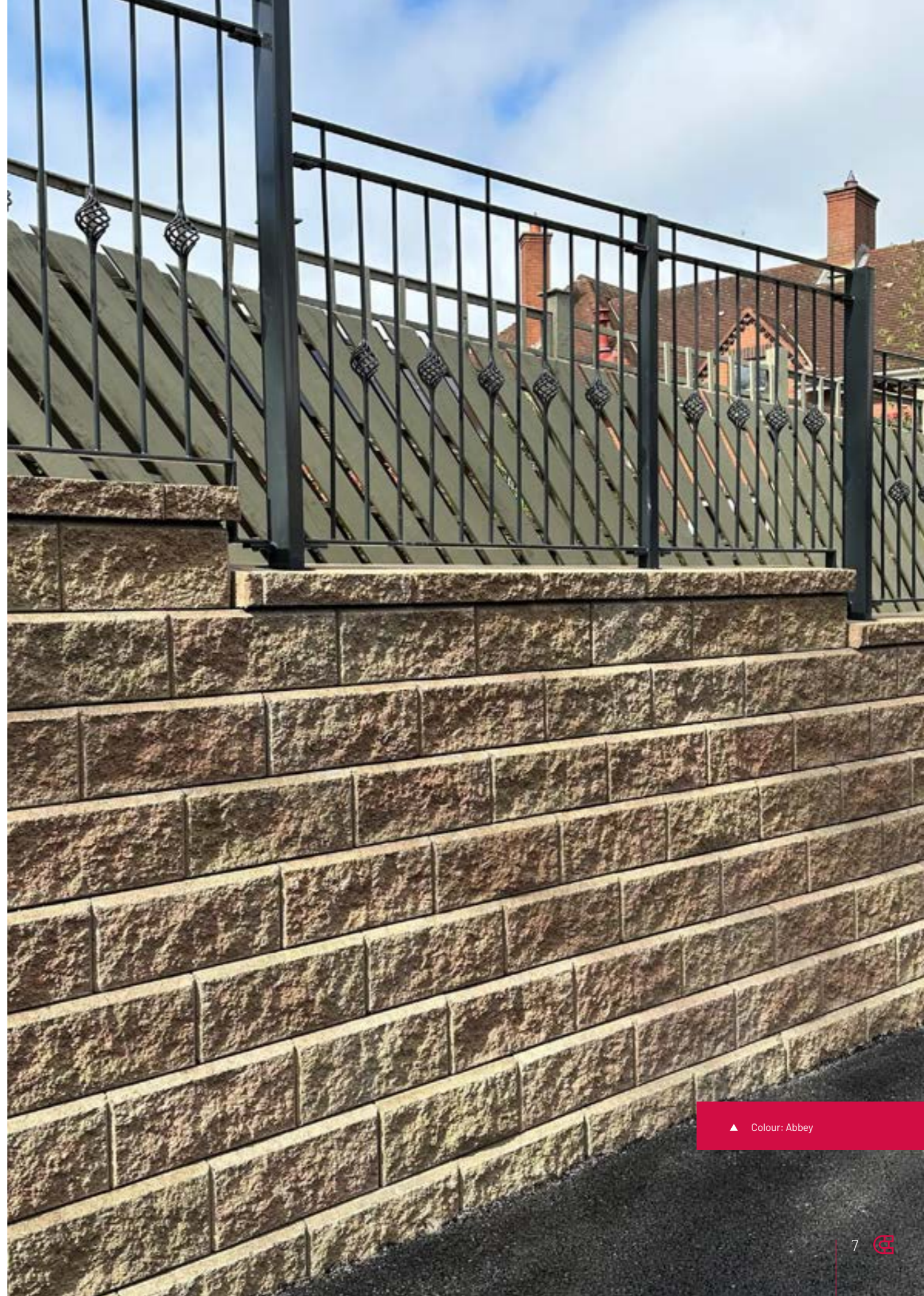

▲ Colour: Abbey



▲ Colour: Abbey

The Allan Block® Collection by Colinwell

Colinwell's Allan Block® range offers a family of retaining wall products designed to meet diverse site and engineering requirements. Each block type features a unique setback angle, allowing you to balance space, strength, and aesthetics in your project.

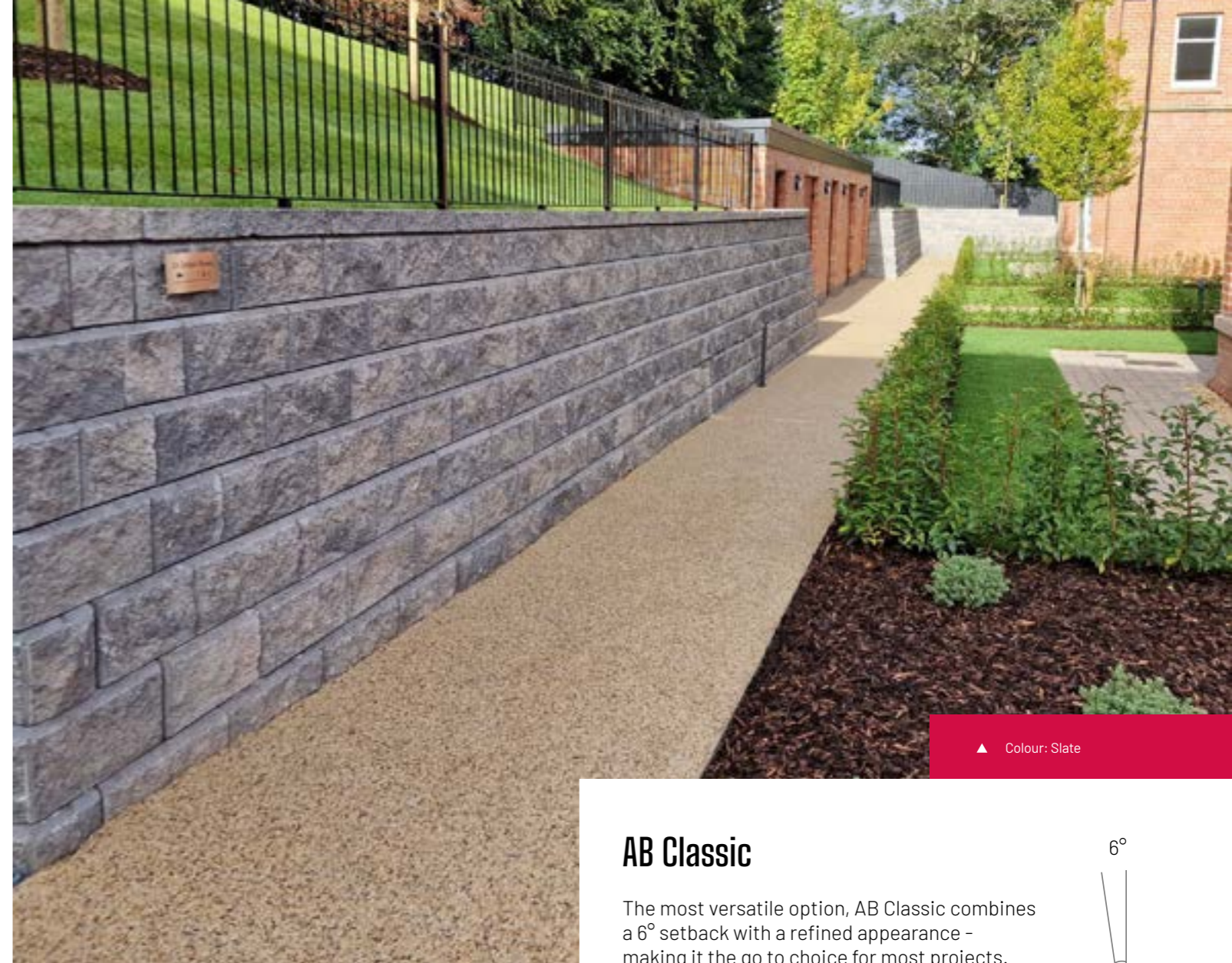

▲ Colour: Slate

AB Classic

The most versatile option, AB Classic combines a 6° setback with a refined appearance - making it the go to choice for most projects.

6°



AB Stones

With a 12° setback, AB Stones provide excellent stability and are ideal for gravity walls. They require more space but offer greater performance.

12°



AB Vertical

Featuring a 3° setback, AB Vertical minimises wall footprint, making it ideal for space constrained sites. It's also available in a special order 1° version for specialist applications.

3°

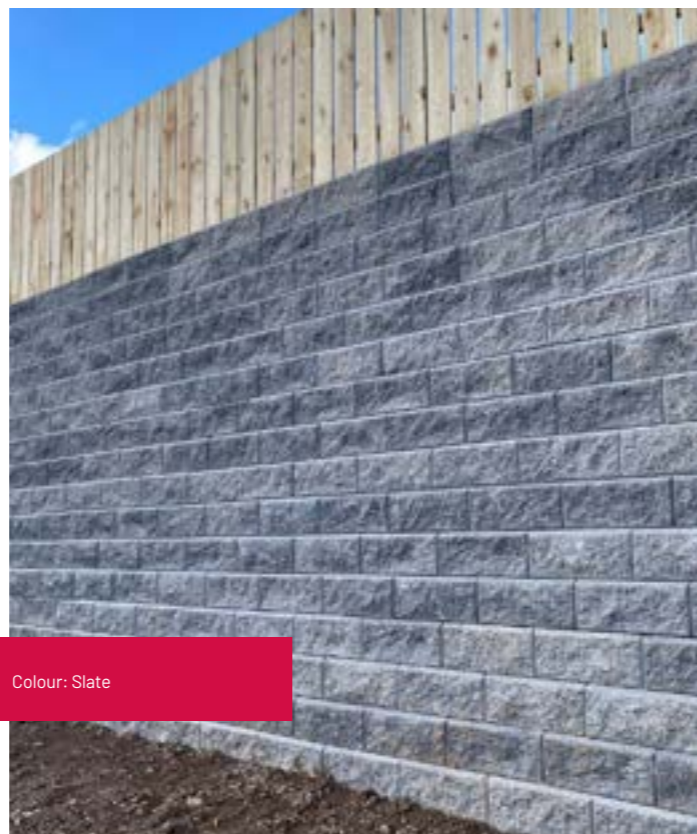

▲ Colour: Slate

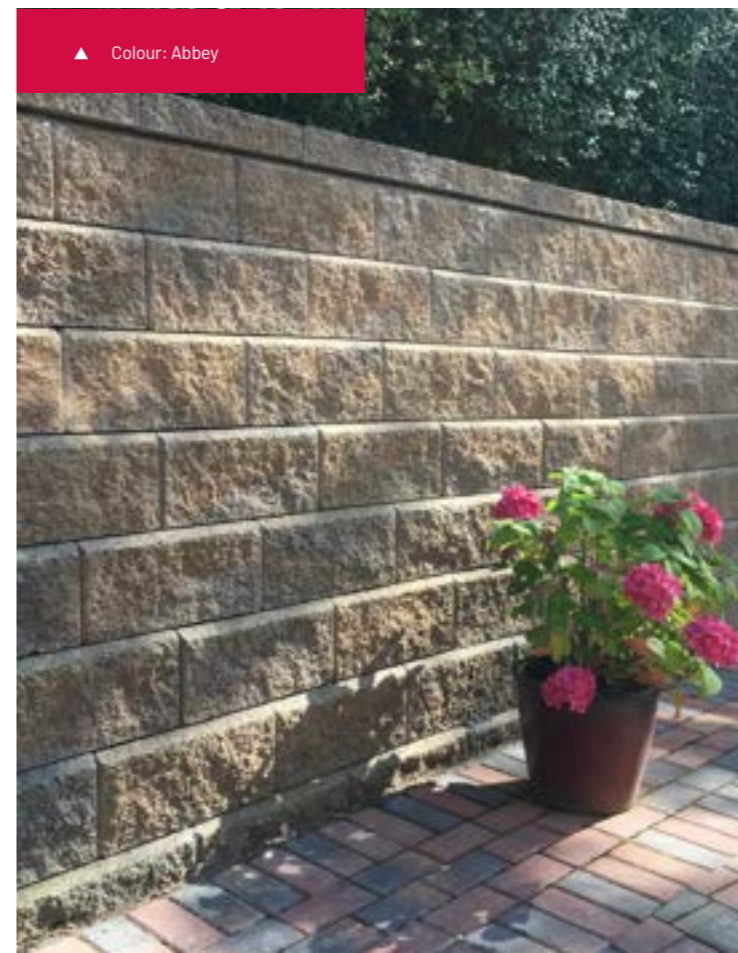

▲ Colour: Abbey

Wall Setback Chart

The backward tilt of a retaining wall is known as the "setback." A greater setback increases the wall's leverage against earth pressure, reduces the amount of reinforcement needed.

The chart below shows how each Allan Block® type offsets from vertical at various wall heights. While AB Stones (12° setback) require more space than AB Classic (6°) or AB Vertical (3°), they offer enhanced stability - making them especially well suited for gravity wall construction.

BlockType	FINISHED WALL HEIGHT				SETBACK
	1.2m	1.8m	2.4m	3.0m	
AB Stones	250mm	380mm	510mm	640mm	
AB Classic	125mm	190mm	255mm	320mm	
AB Vertical	65mm	95mm	125mm	160mm	

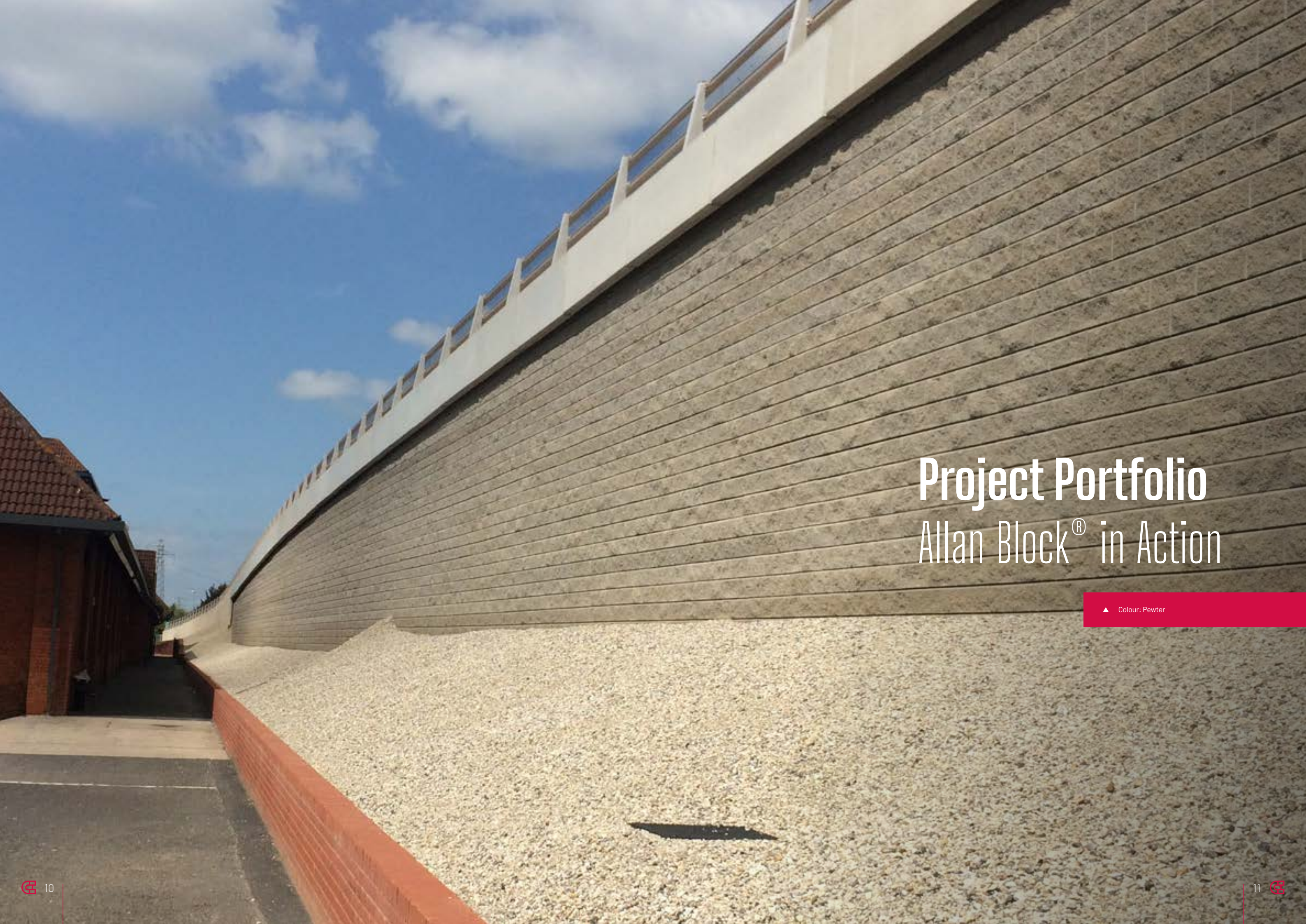

Project Portfolio

Allan Block® in Action

▲ Colour: Pewter

Residential Projects



▲ Colour: Yorkstone



▲ Colour: Slate



▲ Colour: Abbey



▲ Colour: Abbey



▲ Colour: Pewter



▲ Colour: Yorkstone

Education Projects



▲ Colour: Slate

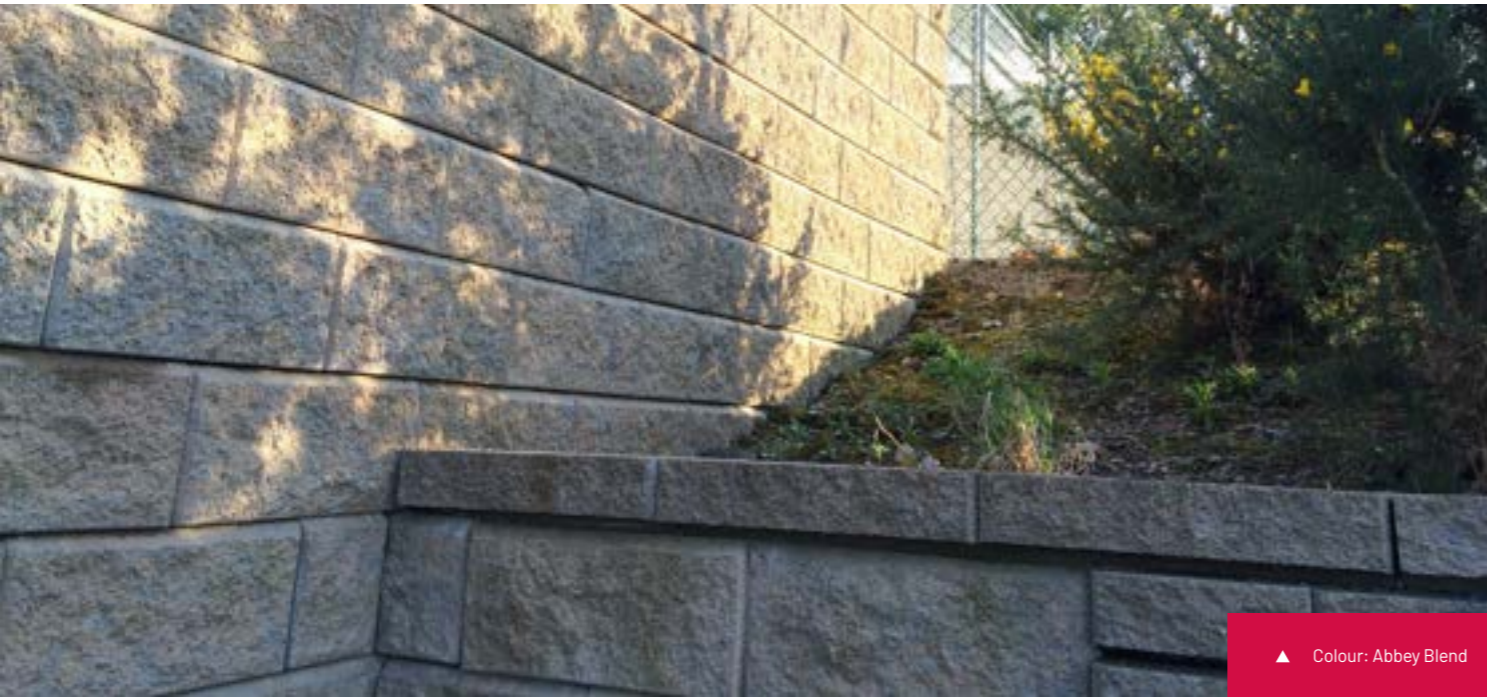

▲ Colour: Abbey Blend

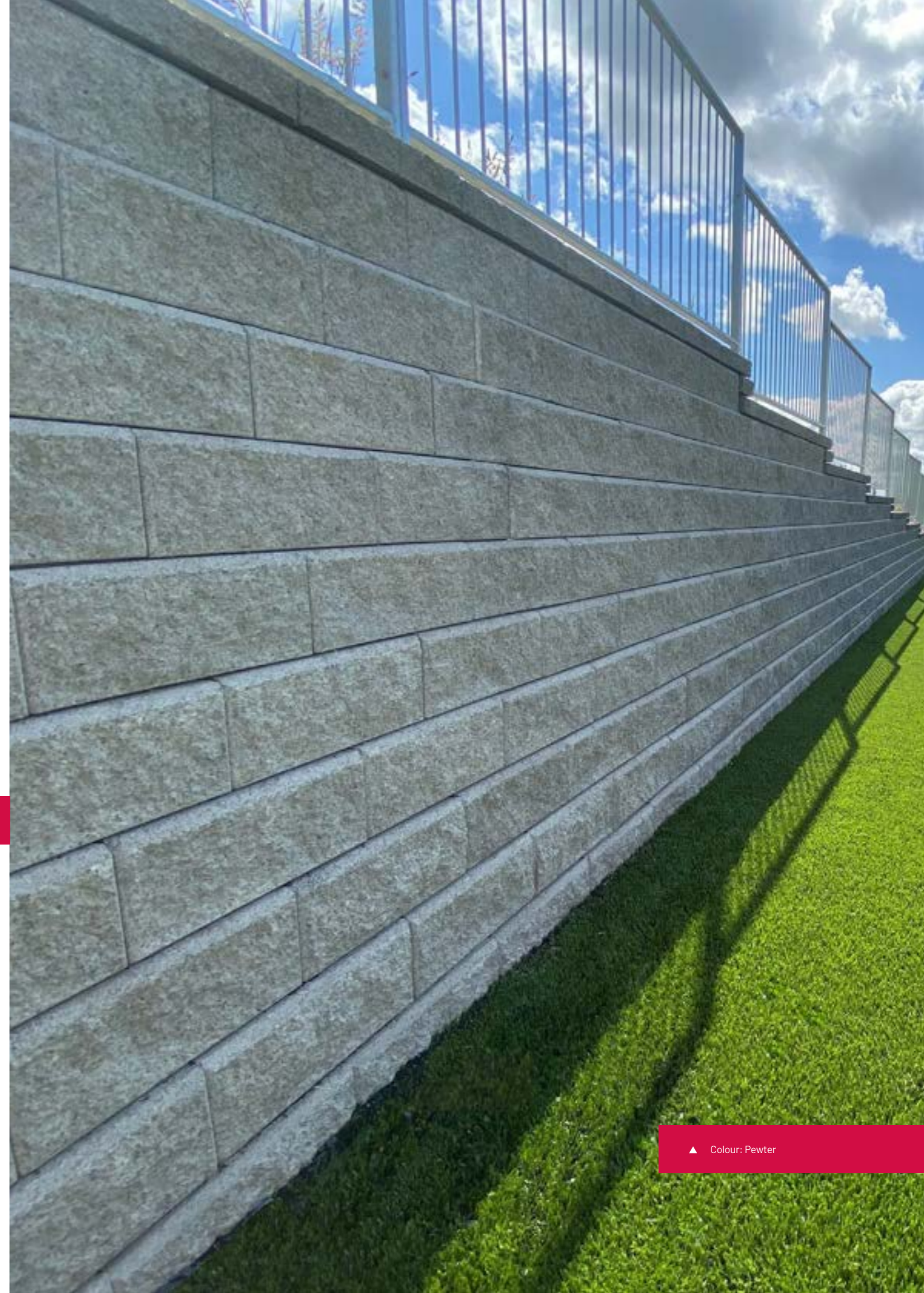

▲ Colour: Pewter



▲ Colour: Pewter

Commercial Projects



▲ Colour: Abbey



▲ Colour: Slate

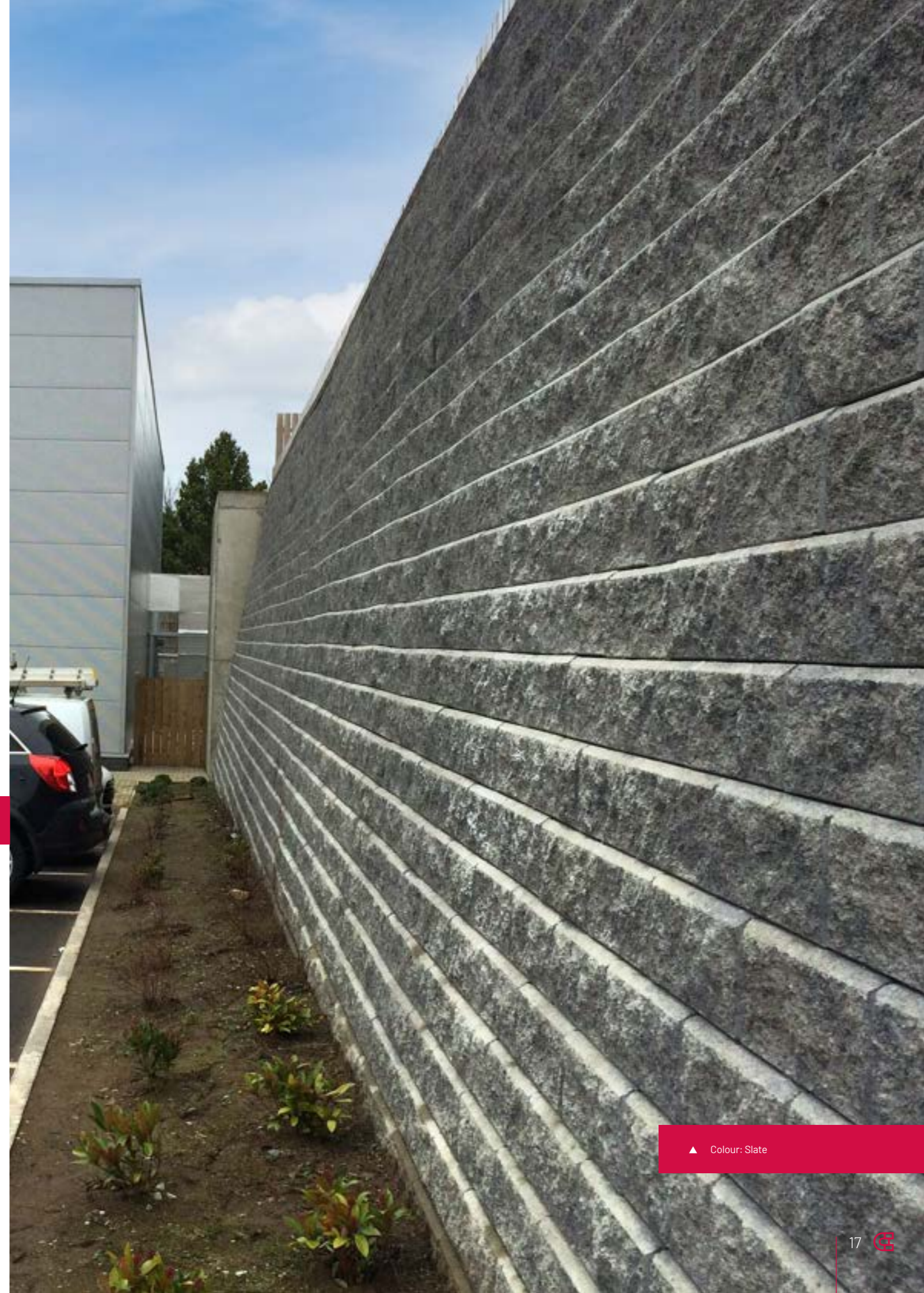

▲ Colour: Slate



▲ Colour: Abbey

Sports & Recreational Projects



▲ Colour: Pewter



▲ Colour: Cinder



▲ Colour: Cinder

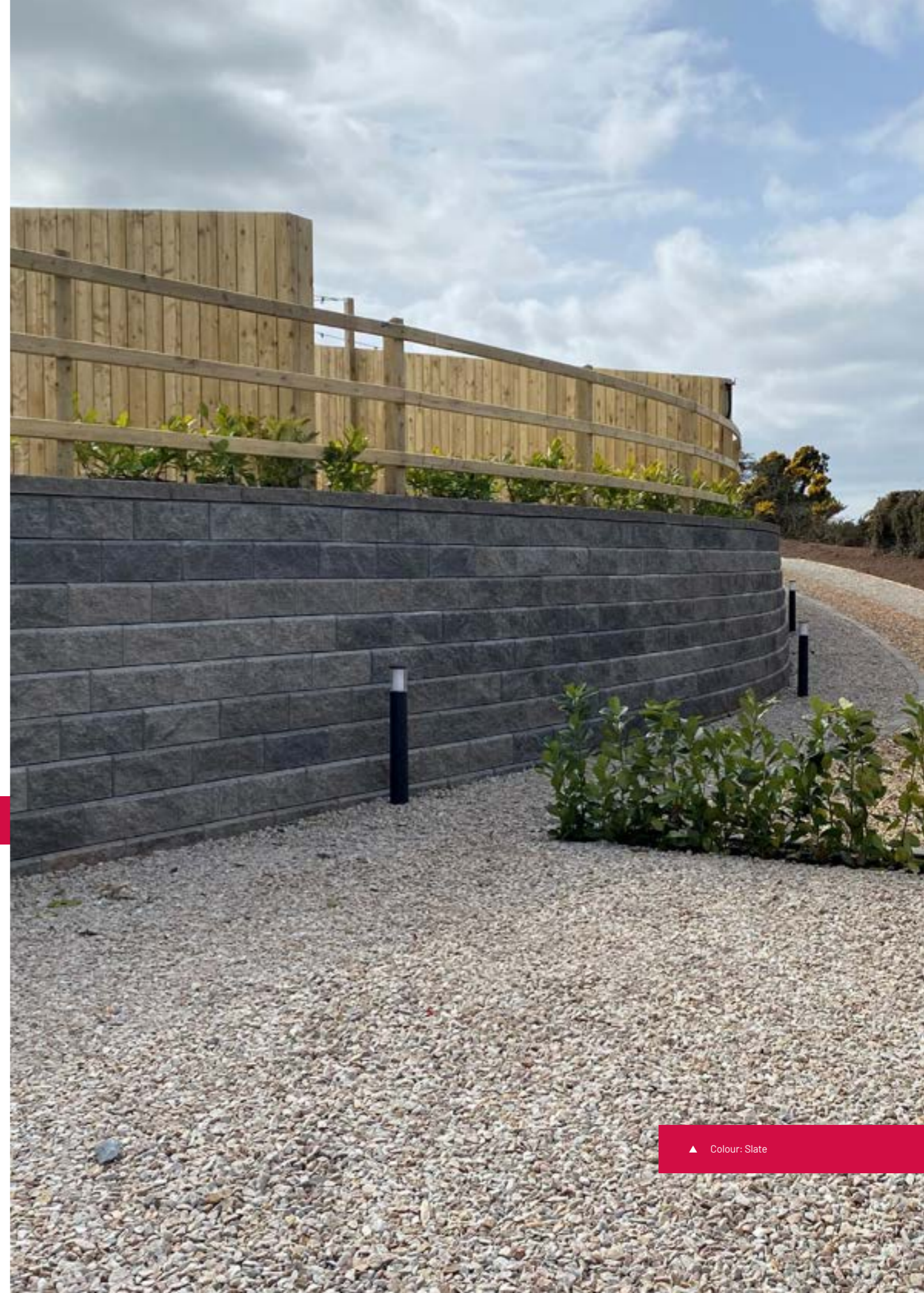

▲ Colour: Slate

Infrastructure Projects



▲ Colour: Pewter



▲ Colour: Pewter



▲ Colour: Pewter



▲ Colour: Abbey

Allan Block® Colour Range

by Colinwell

Please note: Colours shown are as accurate as possible within the limitations of photography and printing. We recommend requesting physical product samples to confirm your final colour selection.



Abbey



Cinder



Pewter



Slate



Yorkstone

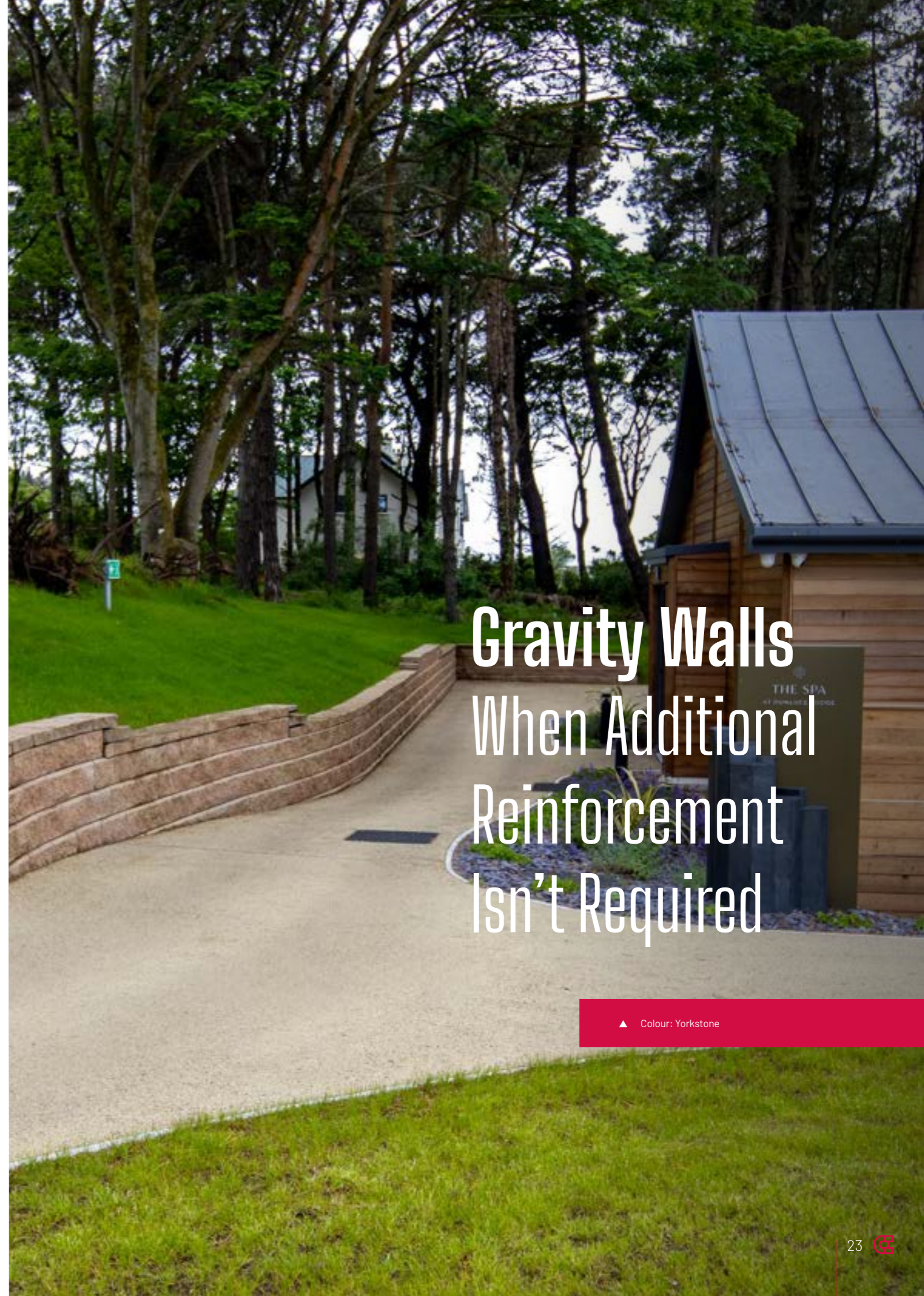

Gravity Walls When Additional Reinforcement Isn't Required

▲ Colour: Yorkstone

Maximum Wall Heights for Gravity Walls

Before constructing a gravity wall, refer to the chart below to determine the maximum wall heights achievable based on the selected block type, the soil being retained, and the conditions above the wall (e.g., slopes or surcharge loads). If there is any uncertainty, we strongly recommend consulting a qualified geotechnical engineer.

Maximum Wall Heights-AB Gravity (Unreinforced) Walls

Condition above retaining wall	Soil Type	Friction Angle	AB Stones 12°	AB Classic 6°	AB Vertical 3°
Level	Clay	27°	1.0 m	0.9 m	0.9 m
	Silty Sand	32°	1.6 m	1.4 m	1.1 m
	Sand/Gravel	36°	1.8 m	1.6 m	1.3 m
Surcharge 100 psf (4.7 kPa)	Clay	27°	0.5 m	0.4 m	0.3 m
	Silty Sand	32°	1.2 m	0.9 m	0.7 m
	Sand/Gravel	36°	1.4 m	1.0 m	0.8 m
Slope 3:1	Clay	27°	0.8 m	0.7 m	0.6 m
	Silty Sand	32°	1.4 m	1.2 m	0.9 m
	Sand/Gravel	36°	1.8 m	1.4 m	1.1 m



Allan Block® Gravity Wall Construction Guide

Full installation guides available on request

How to Build a Gravity Retaining Wall

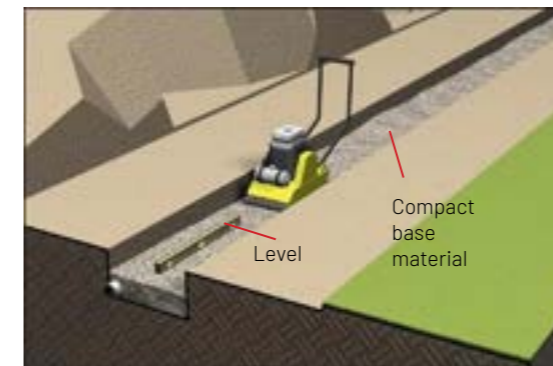

Install base course, level and compact

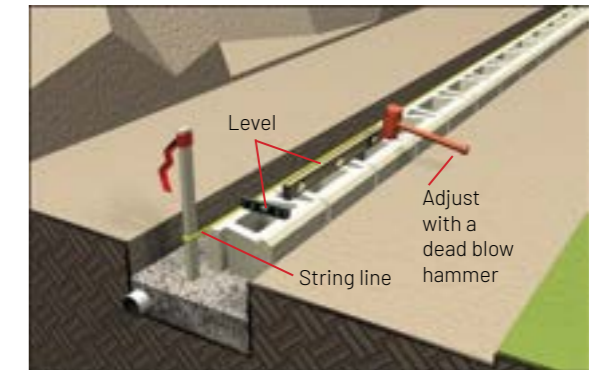

Level blocks, adjust where needed

Installation Process

1. Site Preparation

- Remove all surface vegetation and organic soils.
- Excavate a base trench at least 600mm wide and 300mm deep.
- Ensure that the bottom course of blocks will be buried a minimum of 150mm with compact and level trench.

2. Base Installation

- Place 150mm of graded stone (6-38mm) in the trench and rake smooth.
- Compact and level the base material thoroughly.

3. Laying the Base Course

- Start at the lowest elevation of the wall.
- Place the first course of Allan Block® units on the base, checking for level and alignment.

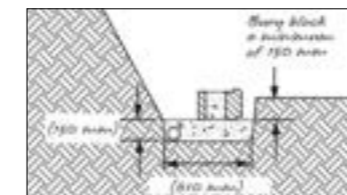

Gravity wall base course cross section

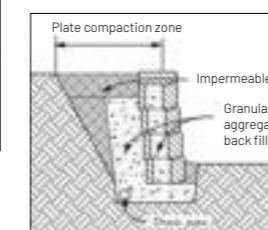

Gravity wall typical cross section

4. Drainage Installation

- Install a drainage pipe - essential for all walls and particularly important in silty or clay soils.

5. Backfilling and Core Fill

- Fill each block's hollow core and a minimum of 300mm behind the wall with drainage stone.
- Use approved material behind the drainage zone and in front of the base course.
- Compact in lifts no greater than one block height (200mm) using a plate compactor.

6. Building Additional Courses

- Remove any loose debris from the top surface of the block before placing the next course.
- Offset each new block course from the one below by at least 75mm (1/4 block length).
- Check and adjust for level and alignment of each unit and the wall batter as the wall stacks up.
- Continue filling the block cores and drainage zone as the wall progresses.
- From the second course upward, compact directly on top of the blocks and the backfill zone in 200mm lifts or less.

7. Finishing the Wall

- Complete the wall to the desired height.
- Cap the wall using 200mm of impermeable soil on the final lift.



Reinforced Walls When Additional Structural Support Is Required

▲ Colour: Pewter

Geogrid Reinforced Wall Solution

Reinforcing Your Allan Block® Wall for Maximum Stability

In some site conditions, the weight and setback of Allan Block® alone may not provide sufficient stability - particularly on taller walls or where additional loads (surcharges or slopes) are present. In these cases, reinforcement is essential.

One of the most effective reinforcement methods is the use of Geogrid, which works by creating a composite structure between the soil and the wall. This increases resistance to lateral earth pressure and allows the construction of taller, more stable retaining walls.

If site constraints limit the use of Geogrid (e.g., property lines or restricted excavation), other reinforcement methods such as No-Fines Concrete or Double-Width Gravity Walls may be considered.

Important:

For all residential walls over 1.8m in height and all commercial retaining walls, we strongly recommend consulting with Colinwell to ensure compliance with structural requirements.

MATERIALS

- Geogrid reinforcement
- Well-graded compactible aggregate (6-38mm, with less than 10% fines)
- Allan Block® Retaining Wall System
- Perforated drainage pipe
- Capstone adhesive (for finishing)



Geogrid reinforcement

EXAMPLE OF ROCK-LOCK

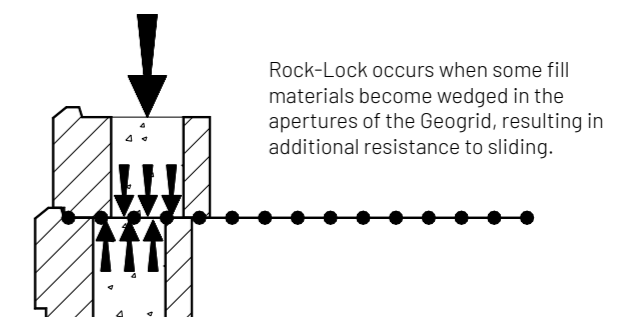

ESTIMATING GUIDE FOR AB BLOCKS

Contact Colinwell's Technical Department for further support.

Approx Wall Height	Wall Length				
	3m	6m	9m	12m	15m
0.2m	7	14	20	27	34
0.4m	14	28	40	54	68
0.6m	21	42	60	81	102
0.8m	28	56	80	108	136
1.0m	35	70	100	135	170
1.2m	42	84	120	162	204
1.4m	49	98	140	189	238
1.6m	56	112	160	216	272
1.8m	63	126	180	248	306

Geogrid Installation Process

Follow these steps to properly install Geogrid reinforcement as part of a reinforced Allan Block® retaining wall:

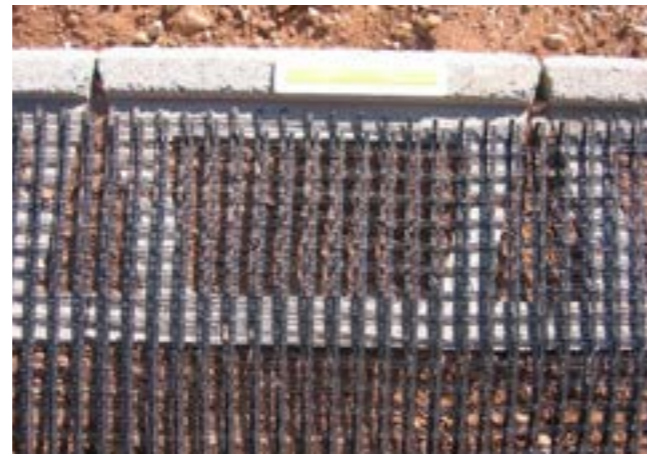

Illustrated: Cut edge placed at back of raised front lip



Illustrated: Geogrid Installation with backfill



Step 1: Cut and Position the Geogrid

- Cut the Geogrid to the specified lengths provided in your wall design.
- Place the cut edge of the Geogrid against the back of the raised front lip of the Allan Block®.
- Roll the Geogrid back over the fully compacted and level excavation area.

Step 2: Stack the Next Course of Blocks

- Place the next course of Allan Block® units directly on top of the Geogrid.
- Offset each course by at least 75mm from the course below. A perfect running bond is not required.
- Ensure each block is tight against the front edge of the block below.

Step 3: Fill Cores and Backfill

- Fill the hollow cores of the blocks and the space 300mm behind the wall with drainage stone.
- Place approved infill soil behind the drainage zone.

Step 4: Compact the Fill

- Compact all materials within 900mm of the wall face.
- Compact in 200mm maximum lifts, beginning on top of the blocks and working backward.
- Never compact directly on the Geogrid.

Step 5: Repeat the Process

- Continue installing additional courses, adding Geogrid layers as specified.
- Install cap blocks once the desired wall height is reached.
- Finish by grading the surface away from the wall to ensure proper drainage.

Tip: Colinwell maintains a stock of both commercial and domestic-grade Geogrid for fast delivery. For full installation details, contact the Colinwell Technical Department for project specific advice.

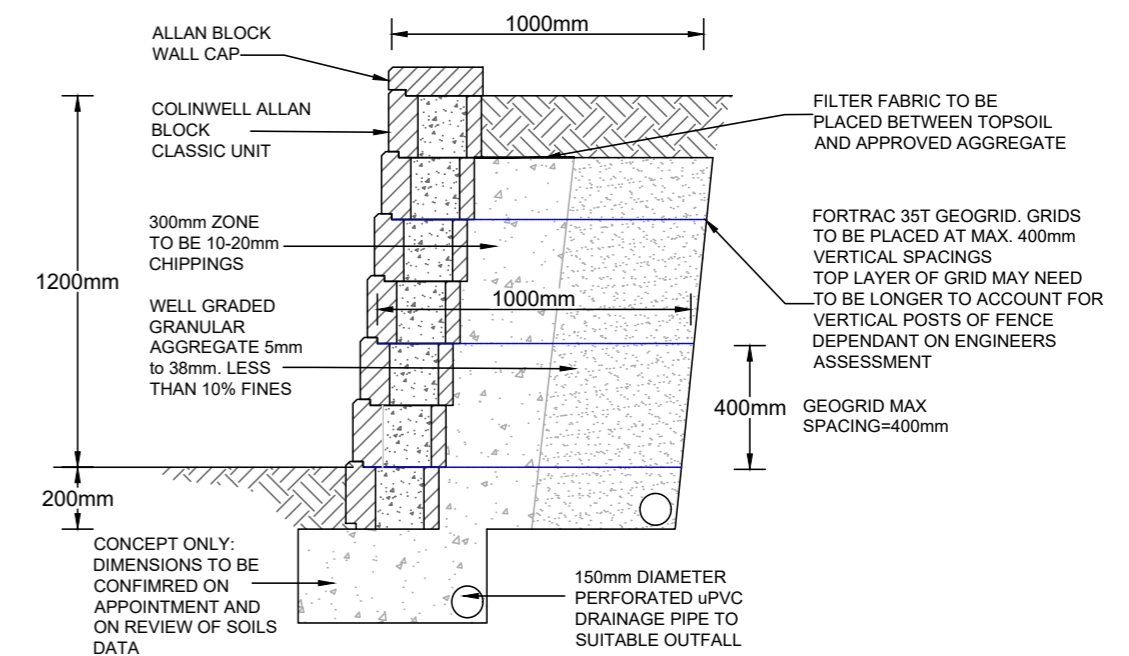

Typical section of a reinforced wall



Geogrid Reinforcement & Continuous Connection

Enhanced Strength for Demanding Retaining Wall Designs

Colinwell's innovative Continuous Connection System offers a superior method of reinforcement for retaining walls subject to substantial loads. The construction process is simple and efficient: wrap the Geogrid around the connection bar nestled within the recesses on the top of the block and then pull it back into place.

While traditional frictional connections between Allan Block® units, Geogrid, and compacted fill are sufficient for most applications, certain high load scenarios demand a more secure solution. The Continuous Connection method provides greater connection strength, improved load resistance, and increased design flexibility - making it ideal for heavily loaded or critical structures.



Positive Connection in use during the installation of Allan Block®

How It Works

- The Geogrid is wrapped around a 16mm extruded PVC bar, which fits into a notched recess at the top of the Allan Block® unit.
- Once wrapped, the Geogrid is pulled back over the compacted backfill to a minimum embedment length of 1.2m.
- The next course of blocks and infill material holds the bar and wrapped Geogrid firmly in place.
- This creates a high-strength mechanical interlock between the wall face and the reinforcement layer.



▲ Colour: Yorkstone

Geogrid Continuous Connection Installation

Installation Process

Step 1: Place the Geogrid

Install Huesker Fortrac T Geogrid according to the wall design, typically at intervals of every two block courses (400mm) or one course (200mm).

Step 2: Create the Continuous Connection

Wrap the Geogrid securely around a 16mm extruded Huesker PVC bar, which is placed into the integrated recess at the top of each Allan Block® unit.

Step 3: Pull Back the Geogrid

Pull the Geogrid straight back into the reinforced soil zone to a minimum embedment length of 1.2 metres.

Step 4: Ensure a Tight Wrap

Take care to wrap the Geogrid tightly around the PVC bar, ensuring it is smooth and free from slack or wrinkles.

Step 5: Continue Construction

Place the next course of blocks on top of the connection. The weight of the blocks and backfill material will lock the bar and Geogrid securely in place.

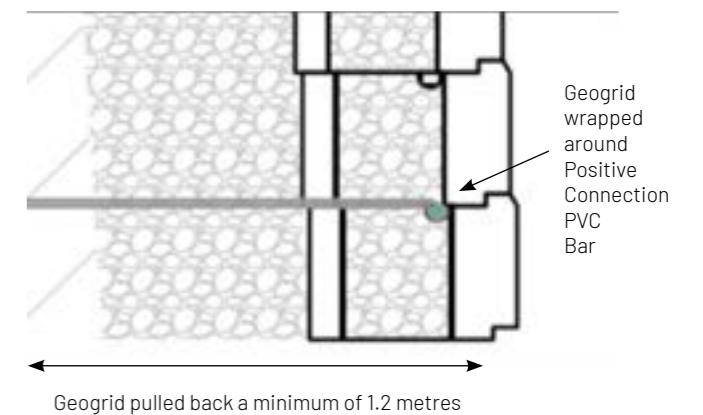

No-Fines Concrete Reinforced Wall Solution

An Efficient Alternative to Geogrid Reinforcement

No-Fines Concrete Backfill offers a reliable and space saving method for reinforcing Allan Block® retaining walls. This permeable concrete mix bonds directly to the back of the blocks, extending the structural depth of the wall and eliminating the need for Geogrid.

This solution is ideal for sites with limited excavation space or property line constraints where traditional Geogrid installation may not be feasible.

Why Choose No-Fines Concrete Reinforcement?

Reduced Excavation Depth

Geogrid-reinforced walls typically require excavation equal to 70% or more of the wall height. No-Fines Concrete reinforcement requires only about 40%, saving both time and space.

Cost-Effective & Versatile

Less excavation means reduced site disruption and lower construction costs, while expanding the range of locations where Allan Block® can be used.

Installation Process

Before placing No-Fines Concrete, follow standard Allan Block® procedures for base trench preparation, levelling pad, and first course installation.

Step 1: Fill the Voids

Pour No-Fines Concrete to fill the block cores and backfill area to the specified depth.

Step 2: Remove One Back Wing (Optional)

For straight wall segments, remove one back wing of each block to improve bond with the concrete.



Illustrated: No-Fines Concrete drainage properties

Step 3: Fill No More Than Two Courses at a Time

Limit each pour to a vertical height of 400mm (two courses) to ensure proper curing.

Step 4: Make Additional Pours

Once the previous lift has set - typically within 2 to 3 hours - proceed with the next pour.

Step 5: Stack Additional Courses

You may continue placing additional courses while the backfill is curing. Brush off any excess material from the top of the blocks before it hardens.

Step 6: Install the Next Course

Level each new course and continue placing No-Fines Concrete as outlined.

Step 7: Repeat the Process

Continue these steps until the wall reaches its final height.



Engineering Properties of No-Fines Concrete Backfill

- The mix typically consists of cement, water, and coarse aggregate, with a cementitious content of approximately 296.6 kg/m³ and a water/cement ratio of 0.30-0.40.
- Designed with 10mm to 20mm aggregate and an aggregate to cement ratio of 6:1.
- The density of the mix varies depending on the aggregate used but generally falls between 1950-2160 kg/m³.
- No-Fines Concrete has minimal slump, behaving similarly to loosely poured stone during placement. It exerts pressure on the wall and surrounding soil until it cures - typically within 24 hours.
- The backfill zone filled with No-Fines Concrete also acts as the wall's internal drainage system, serving both the block cores and the area directly behind the wall.

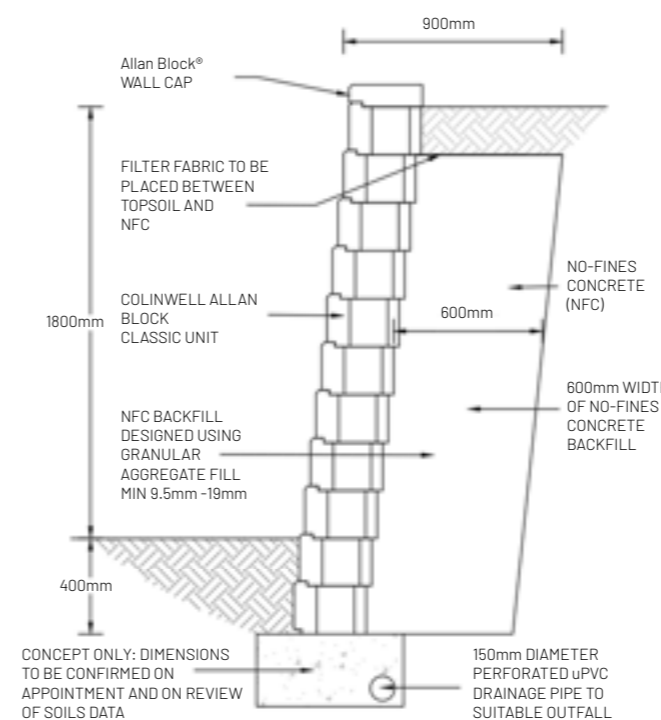

Illustrated: No-Fines Concrete installation on site



Wall Detailing Techniques for Finishing Retaining Walls

▲ Colour: Pewter

Steps

How to Construct Steps

Step 1: Excavate and Prepare the Base

- Excavate the required depth and width for each step riser.
- Use a plate compactor to compact the entire area thoroughly.

Step 2: Check for Level

- Ensure the excavated area is level before continuing.

Step 3: Place Granular Aggregate Fill

- Fill the first step with 150mm of well graded granular aggregate and rake it smooth.
- Compact the area and recheck for level.
- Stair construction requires extra compaction to prevent future settlement.

Step 4: Install the First Course of Blocks

- Set the Allan Block® units directly on the compacted granular fill, allowing for a 150mm backfill zone behind the blocks.
- Check that each block is level and properly aligned as you install.

Step 5: Fill and Backfill

- Fill the block cores and all spaces in front of and behind the blocks with granular aggregate.
- Backfill the entire excavated area behind the riser to establish a solid, level base for the next step.
- We recommend backfilling and compacting in 100mm lifts to achieve maximum compaction.

Step 6: Compact and Level the Fill

Rake the surface smooth, then compact the fill with a plate compactor, making your first pass directly on top of the blocks and moving parallel to the wall face.

Step 7: Repeat for Additional Steps

Continue this process for each subsequent course of steps until the desired stair height is achieved.

How Many Steps?

To find the number of steps needed, measure the total rise of your slope in mm and divide by 200mm which is the height of the step.

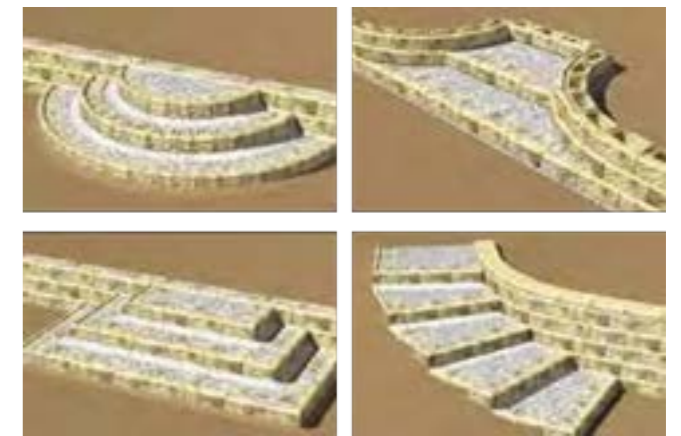

Excavate for stairs and compact.

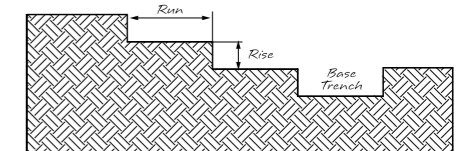

Install and level block on base material.

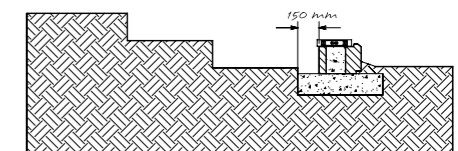

Backfill block cores and behind block with wall rock. Compact.

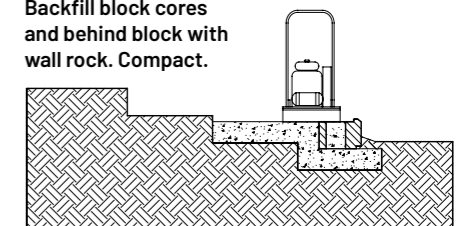

Install next stair course.

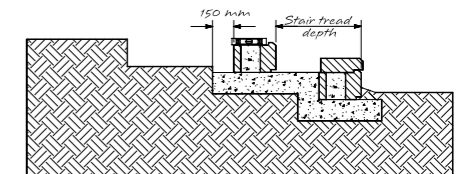

Continue for each new stair.

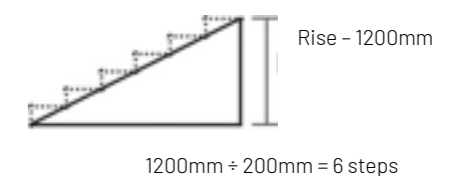
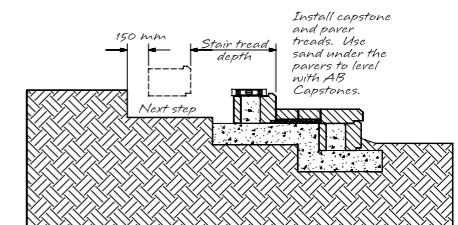

Corners

How to Construct an Inside Corner

Step 1: Modify the First Block

Remove half of the raised front lip from one block on each course using a diamond blade saw or chisel. This allows the next course to sit level over the corner.

Step 2: Position the Modified Block

Place the modified block perpendicular to an adjacent AB unit to form the inside corner.

Step 3: Alternate Lip Removal on Each Course

On the next course, remove the opposite half of the raised lip from another block. Position this block over the right angle to continue the interlocked corner bond.

Step 4: Repeat as Needed

Continue alternating the lip removal on each successive course to maintain alignment and create a strong, interlocked inside corner.

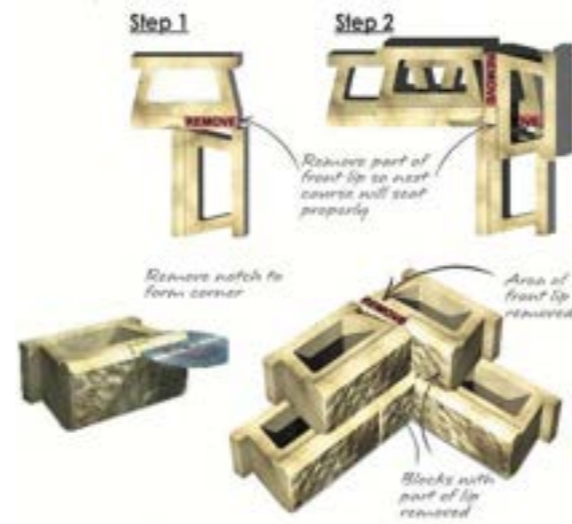

How to Construct an Outdoor Corner

Left-Handed Corner Units

When viewed from the front, the finished/textured end of a left-handed corner unit appears on the left side.

Right-Handed Corner Units

When viewed from the front, the finished/textured end of a right-handed corner unit appears on the right side.

Corner Building Tips

- Always begin construction at the corners and work outward in both directions.
- Set the first corner block in place, then install the two perpendicular base courses.
- Level, backfill, and compact thoroughly.

On the second course:

- Place an alternating corner block to interlock with the course below.
- Continue laying the second course in both directions.
- Level, backfill, and compact again.
- Repeat this process for each course until the wall reaches its full height.

Adapting Corner Units to Different Setbacks

Corner units are manufactured with a 12° setback. However, they can be modified for use with:

- AB Classic (6° setback)
- AB Vertical (3° setback)

Modification Example:

To adjust a corner block for use with AB Classic, cut a 20mm notch into the short side of the block using a suitable masonry tool.

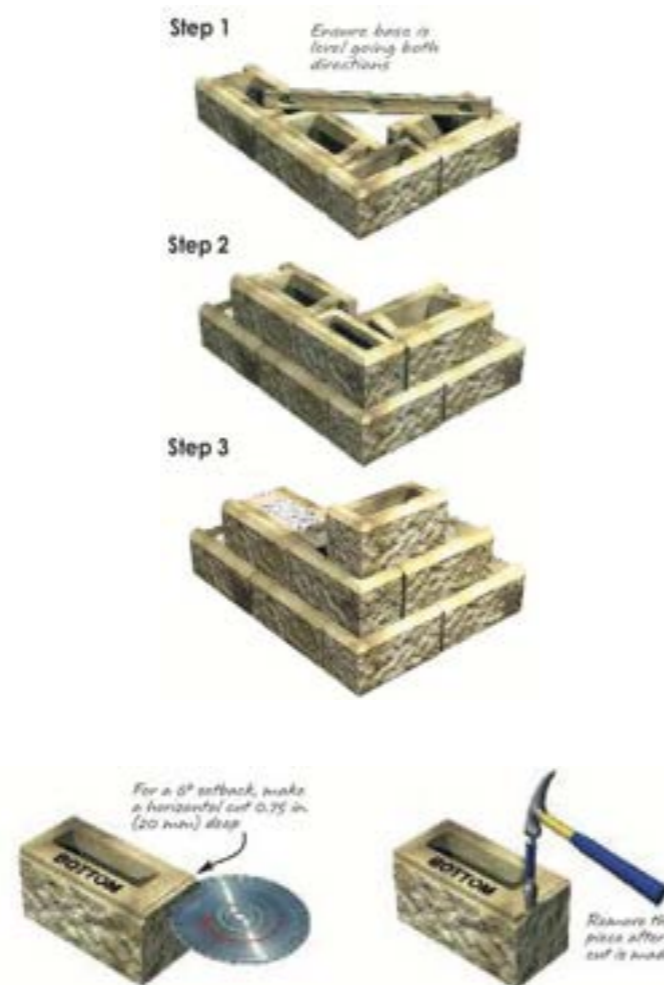

Curves

Curved retaining walls add visual interest and blend naturally into the landscape. With Allan Block®, curves are easy to design and simple to build. Whether you prefer tight or gentle sweeping arcs, selecting the right block or combination of blocks is key to a successful design.

Refer to the Radius Chart (see page 38) to help you plan and build to the correct specifications.

Offset the Vertical Seams

To ensure structural integrity and a smooth appearance, maintain an offset of at least 1/4 of the block length between vertical seams on each course - this applies to both inside and outside curves. Using half-length blocks (AB Junior) or cutting full blocks in half can help achieve the proper offset where needed.

Before construction begins, lay out your wall design. Measure the radius of each curve and refer to the Radius Chart to confirm compatibility with your chosen block type. If needed, adjust your layout to match the block system.

As a general guideline, gentle, sweeping curves tend to create the most aesthetically pleasing and visually balanced retaining walls.

Inside Curves

To build a flowing inside curve, keep the front of the blocks tight together and fan out the blocks keeping the space consistent between the backs of the blocks.

Outside Curves

To build smooth outside curves, remove one or both of the "wings" from the back of the blocks and tighten the radius of the curve. To obtain a clean break, hit the back of the wings with a hammer.

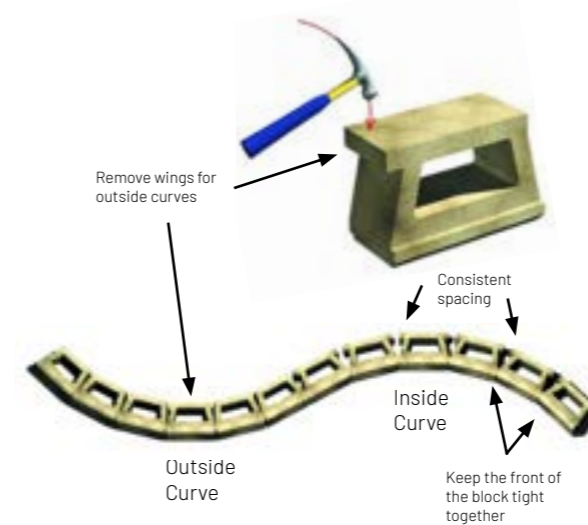

Cutting the bottom notch for tighter outside curves

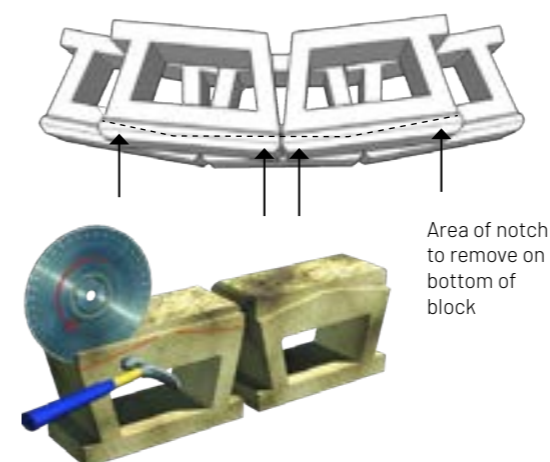

Cutting the bottom notch for tighter inside curves

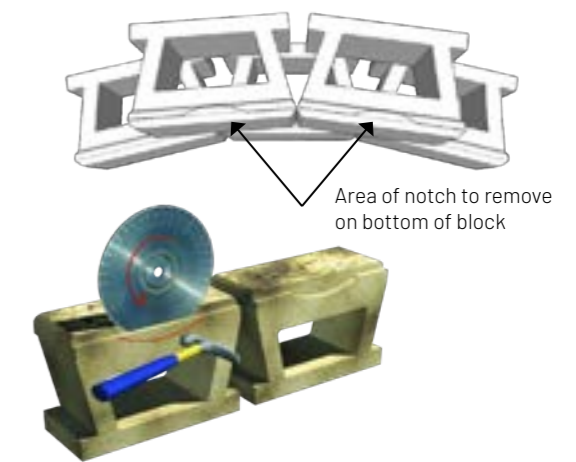

Ending and Topping Off Walls

AB Radius Chart for the Base Course				
Setback	Wall Height			
Full Length Blocks (450mm Long)	1.2m	1.8m	2.4m	3.0m
3°	1.43m	1.52m	1.6m	1.7m
6°	1.6m	1.7m	1.8m	1.9m
12°	1.7m	1.8m	2.0m	2.1m
Half Length Blocks (225mm Long)	0.6m	1.2m	1.8m	
AB Juniors 6°	0.9m	1.0m	1.15m	



Determining the Radius

Curved walls require a greater setback, which results in a coning effect. This means the retaining wall will have its tightest radius at the top, necessitating a larger radius at the base course to maintain stability. The final height of the wall will dictate the minimum radius needed at the base. Refer to the radius chart to identify the minimum recommended radius for the base course of the wall.

Base Course Radius for an outside curve on a 1.2m tall 6° wall

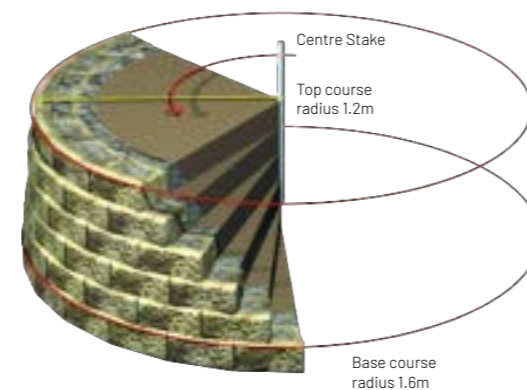

Starting The Curve

To begin forming the curve, identify the starting point along the wall. From that point, measure straight back the distance specified in the radius chart and place a stake in the ground - this marks the centre of the curve.

Tie a string to the stake, using a length equal to the desired radius, and swing it around in an arc to mark the position of the base course.

Place the base course blocks so that their fronts align with this arc.

When transitioning from the curve to a straight section or another curve, lay out the curve and the first few blocks of the next section. Slightly adjusting one or two of these blocks will help create a smooth and natural transition.

Building Tighter Curves

Use the AB Junior whenever possible to build tighter curves within the wall. When using full size blocks, it may be necessary to remove parts of the bottom notch to fit the blocks closer together.

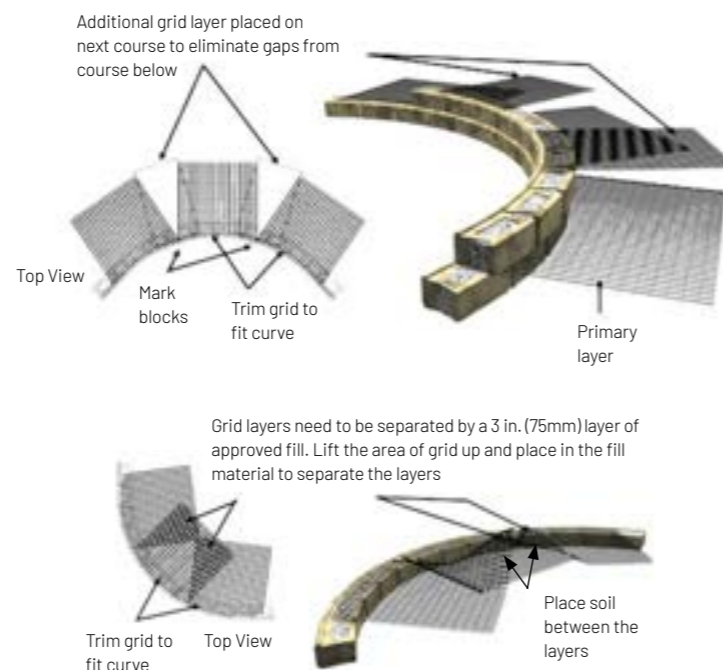

Allan Block® provides a wide range of attractive finishing options to complete your wall. The patented raised front lip of Allan Block® offers a built-in edge that neatly contains landscape materials like stones, bark, grass, or soil.

To finish the top of the wall, AB Capstones can be installed. For best results, secure them in place using a high-quality, waterproof, flexible masonry adhesive.

Creating Turn-Ins

To give your wall a graceful, natural looking end, consider curving it inward to form a plantable area that softens its appearance.

When constructing a turn-in, be sure to excavate, backfill, and compact a base trench - just as you would when installing the base course of blocks.

Creating Step Downs

Walls with step downs can be easily finished by turning the corner blocks back into the hillside.

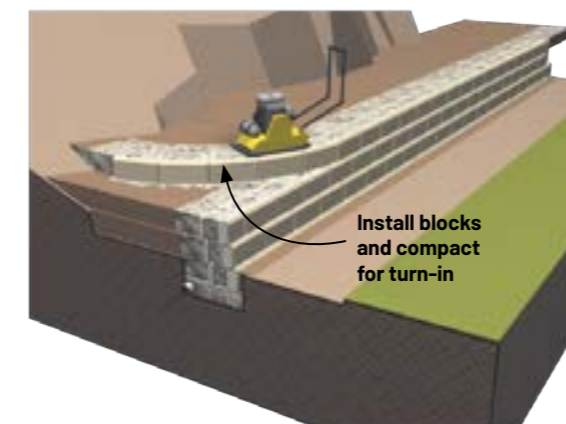
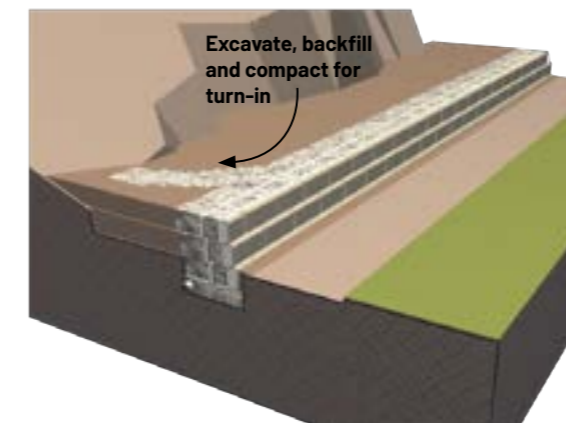

Figure 1: For a full course step-down, use the AB Corner Block.



Figure 2: Flowing turn-in of wall.



Figure 3: For a step-down that doubles as a planter, turn the wall in 2 or 3 blocks after the AB Corner Block.



Figure 4: For a natural flow into the landscape, curve the wall back into the hillside.

Terracing

Finishing Walls with Terracing

In many cases, replacing one large retaining wall with multiple shorter terraced walls offers a more visually appealing solution. However, terraced walls can exert additional pressure on each other, potentially leading to global instability. As a result, reinforcement may be required. Always consult a qualified local engineer when planning or constructing terraced walls.

Retaining walls may be built without engineering support if they function independently. This generally applies when the space between the walls is at least twice the height of the lower wall, and the upper wall is no taller than the lower wall.

Engineering evaluation is necessary for:

- Walls that require geogrid reinforcement
- Terraces spaced closer than twice the height of the lower wall
- Projects involving more than two terraces
- Walls with structures or additional loads above

Terraced walls that do not act independently must also be analysed for global stability. In such cases, the lower walls must be designed to support the load from the upper walls.



Reinforced Terraced Wall Section

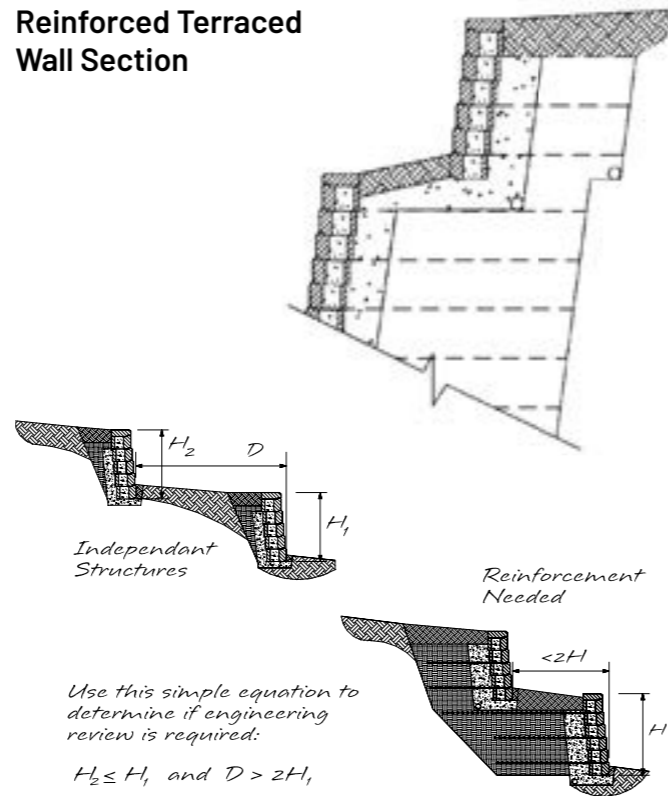

▲ Colour: Abbey



▲ Colour: Abbey Blend

How to Specify

Dimensions (W x D x H)

Standard Block: 450 x 300 x 200 mm

Setback Options

AB One: 1° Batter
 AB Vertical: 3° Batter
 AB Classic: 6° Batter
 AB Stone: 12° Batter

Compressive Strength

Standard Block: 30N/mm²
 BBA Block: 40N/mm²

Density

Standard Block: 2100 kg/m³
 BBA Block: 2200 kg/m³

Unit Type

Hollow Core

Absorption Rate

3-6%

Weight (Approx.)

Standard Block: 35 kg

Face Coverage (Approx.)

11 m²

Bond

Stretcher

Finish

Split Face Texture

Available Colours

Abbey, Cinder, Yorkstone, Pewter, Slate

Special Shapes

AB Wall Cap: 450 x 300 x 100 mm (Approx. 27 kg)

AB Corner Block: 400 x 200 x 200 mm (Left/Right Handed, Approx. 26 kg)

AB Junior: 225 x 240 x 200 mm (Approx. 18 kg)

Accessories

Reinforcement may be required. Contact Colinwell's Technical Department for guidance.



Scan to specify Colinwell's products to your project on NBS



Clamp tool to lift Allan Block®s

Our Accreditations



Allan Block® has been awarded the BBA (Roads & Bridges) Accreditation, confirming its suitability for use on infrastructure projects throughout the UK. In accordance with regulations from the Highways Agency (Great Britain) and Roads Service (Northern Ireland), all retaining walls located within 6 metres of a road boundary or supporting a roadway must have full TAS (Technical Approval for Highway Structures) Approval. Allan Block® meets these requirements and has been successfully installed across both the UK and the Republic of Ireland.



Certified under the Highway Authority Product Approval Scheme, Allan Block® is approved for use on road and transportation infrastructure managed by UK highway authorities.



Colinwell proudly holds Level 2+ Accreditation in Factory Production Control from the NSAI (National Standards Authority of Ireland). This certification supports our commitment to quality and consistency across our supply chain in the Republic of Ireland.



We are dedicated to delivering high quality products, exceptional service, and customer satisfaction. To support this commitment, we have developed robust Quality Management Systems, which have earned us the internationally recognised ISO 9001 Quality Management Accreditation.



Colinwell takes environmental responsibility seriously. Our materials have contributed to the construction of numerous landmark projects throughout the UK and Ireland. As part of our commitment to sustainable business practices, we hold ISO 14001 Environmental Management Certification - reflecting our efforts to minimise environmental impact and support future generations.



Allan Block® Retaining Wall Systems carry CE Marking, demonstrating compliance with EU legislation and confirming that our products meet all applicable European health, safety, and environmental protection standards.

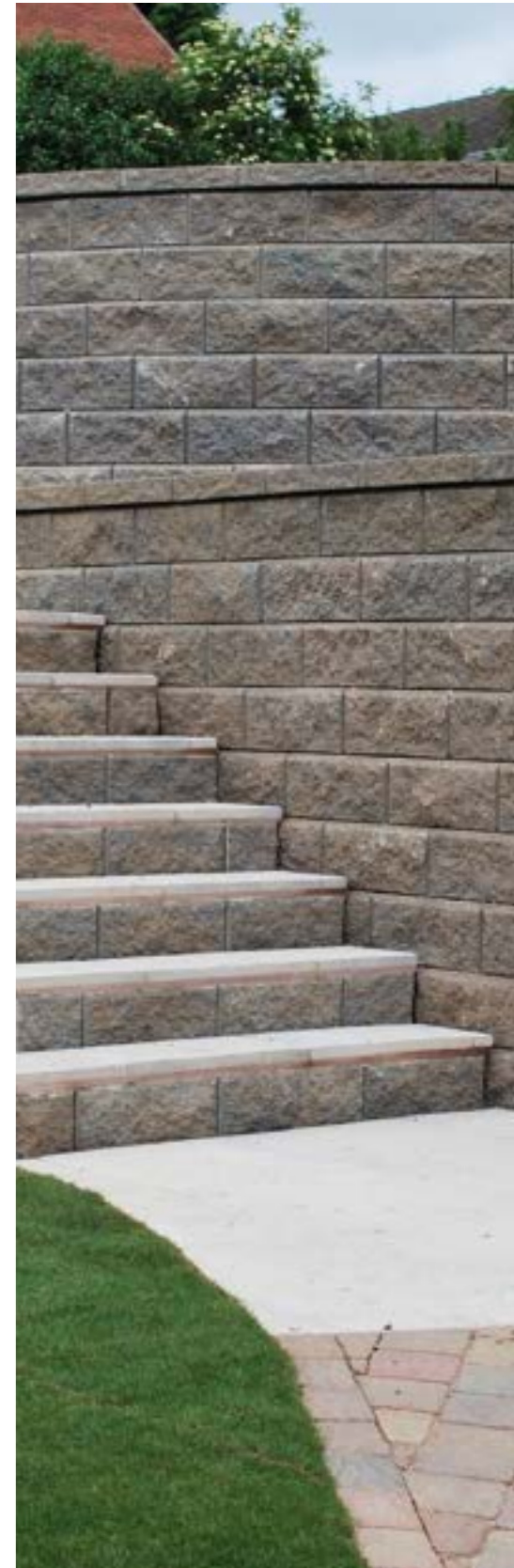

Colinwell

37 Colinglen Road, Dunmurry
Belfast, BT17 0LP



Contact Us

www.colinwell.com
info@colinwell.com
Northern Ireland: 028 9061 8145
Ireland: 00353 1 906 1801
England: 0113 350 0880
Scotland: 0141 319 4759

Colinwell 
Masonry & Retaining Wall Products